

oventrop

Innovation + Quality

Valves, controls + systems

Thermal solar energy
Stations, controllers, collectors, accessories,
service, software

Product range

Award:



MADE IN GERMANY



Content

Page

2	Content
3	Significance of solar energy
4	Solar hot water preparation and support of the heating system
5	Tube collector "OKP-10/20"
6	Flat-plate collector "OKF"
7	Stations "Regusol-130"
8	Stations "Regusol-180"
9	Station "Regusol X-Uno" with heat exchanger
10	Station "Regusol X-Duo" with heat exchanger
11	Hot water preparation and support of the heating system – Buffer storage cylinder and station for heating of potable water "Regumaq X" – System illustration
12	Hot water preparation and support of heating system – Buffer storage cylinder and station for heating of potable water "Regumaq X" – Loading section by section with station "Regusol X-Duo" – System illustration
13	"Regumaq X-30-B/XZ-30-B" Stations for heating of potable water
14	"Regumaq XK" Cascade control set for heating of potable water – Control concepts
15	"Regtronic" Controllers for solar and heating techniques
16	"Regtronic" Electronic controllers – Pipework configurations, examples
17	"Regucor WHS" Energy storage centre, "Hydrocor" Storage cylinders
18	"Solar" Diaphragm expansion tanks, inline tanks – Pipes and fittings
19	Further products for thermal solar energy
20	Service, software



Example: Construction of a solar plant in a detached house

Stations for solar plants and solid fuel boiler connection are becoming more and more important.

The reasons are not at least the rising energy prices and the changing environmental consciousness of consumers.

These stations are not only installed in new buildings, but also existing systems are increasingly converted.

The use of solar energy for heat generation is a good opportunity to reduce energy costs in combination with gas/heating oil gross calorific boilers.



1



2



3

Fossil fuel reserves will become more and more important over the next few years and for this reason regenerative energy sources will become vital.

For the good of the next generations, the climate targets and the reduction of CO₂ emissions must become the responsibility of everyone in our society.

Solar energy helps to conserve resources, is available to a sufficient extent and helps to avoid CO₂ emissions.

Solar energy is thus one of the most promising energy sources and should be used to full advantage.

All over the world, solar plants become more and more important for hot water preparation and heating system support.

Solar plants require little maintenance. They are not only crisis-proof and a calculable future investment but also enable their users to circumvent oil and gas price increases to a certain extent. Last but not least, solar plants create work places.

Advantages of solar plants:

- protection of the environment as resources are conserved and CO₂ emissions are avoided
- increased value of real estate
- increased independence
- crisis-proof

Oventrop systems for solar thermal energy are suitable for hot water preparation, heating system support and process heat supply.

The Oventrop solar systems and components such as collectors, stations and accessories can be combined with existing appliances which need not be replaced.

The systems allow for individual solar plant configurations.

The common solar plants are not only used for hot water preparation but also for heating system support. As a major part of energy in a house is used for the heating system, the combination "hot water preparation plus support of the heating system" offers the highest potential of energy saving.

1 Detached house with solar plant

2 Vacuum tube collector field, flat roof installation

3 Vacuum tube collector plant, wall installation



1

Solar hot water preparation

During the summer months, the energy required for hot water preparation can be covered completely by a professionally dimensioned and installed solar thermal plant.

The Oventrop solar thermal system for hot water preparation consists basically of the following main components:

1. the collector field consisting of "OKP" vacuum tube collectors or high-capacity flat-plate collectors "OKF"
2. the solar station "Regusol" with integrated control for heat transport and the necessary safety devices
3. the solar buffer storage cylinder or bivalent potable water storage cylinder

Function of a solar thermal plant for hot water preparation

The heat transfer liquid is heated by the sun via the collector absorber. The solar liquid is transported by the station's circulation pump to the lower heat exchanger, for instance a bivalent potable water storage cylinder, where heat is transmitted to the potable water.

The circulation pump in the solar circuit is only activated by the solar controller if the temperature in the collector is higher than the temperature in the lower section of the storage cylinder. The temperature difference is detected by temperature sensors at the collector and the bivalent storage cylinder.

Depending on the temperature difference, the flow rate of the solar liquid is increased or reduced. This way, an optimum solar heat return and suitable temperatures inside the storage cylinder are achieved.

In central Europe up to 60-70% of the energy demand for hot water preparation can be saved.

If solar radiation is not intense enough for hot water preparation, the required energy must be supplied by another heating system.

- 1 Basic illustration of a solar plant for hot water preparation
- 2 Switching diagram with bivalent potable water storage cylinder

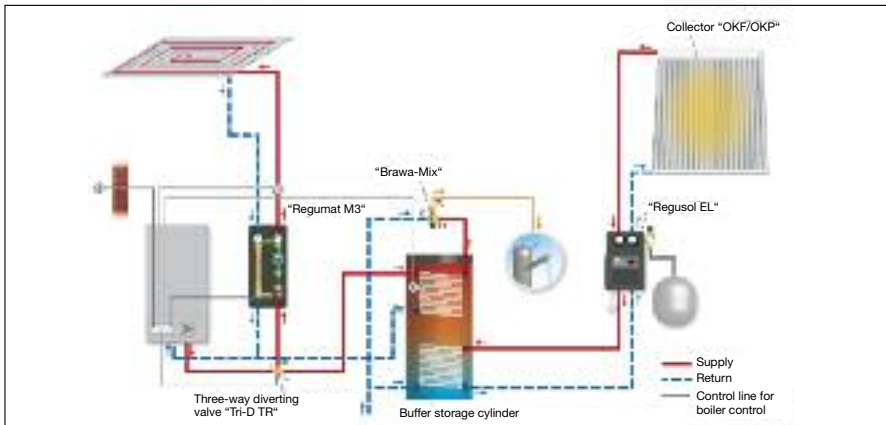

2



3

Solar hot water preparation and support of the heating system

The Oventrop solar thermal system for hot water preparation and support of the heating system consists of the following main components:

1. the collector field consisting of "OKP" vacuum tube collectors or high-capacity flat-plate collectors "OKF"
2. the solar station "Regusol" with integrated control for heat transport and the necessary safety devices

The existing boiler can also be blocked or activated.

3. the solar buffer storage cylinder and the buffer storage cylinder

Function of a solar thermal plant for hot water preparation and support of the heating system

The function of a solar thermal plant for support of the heating system is similar to that of a solar plant for hot water preparation described before. The collector surface of a solar plant for support of the heating system is larger than that for hot water preparation only.

Correctly dimensioned and installed solar plants can supply up to about 15 – 20% of the total energy demand (hot water preparation and support of the heating system). Heat storage is different. The heat is stored in solar buffer storage cylinders for instance. Hot water preparation is carried out by heat exchanger stations "Regumaq X".

Integration of the heating system is frequently carried out by a return temperature increase of the heating circuit. If the temperature in the storage cylinder is higher than the heating return temperature, a three-way diverting valve "Tri-D TR" is operated and leads the heating return through the storage cylinder where it heats the water. If the storage cylinder temperature is too low, the heating return is warmed up by the conventional heating system.

- 1 Basic illustration of a solar plant with heating system support
- 2 Switching diagram with return temperature increase

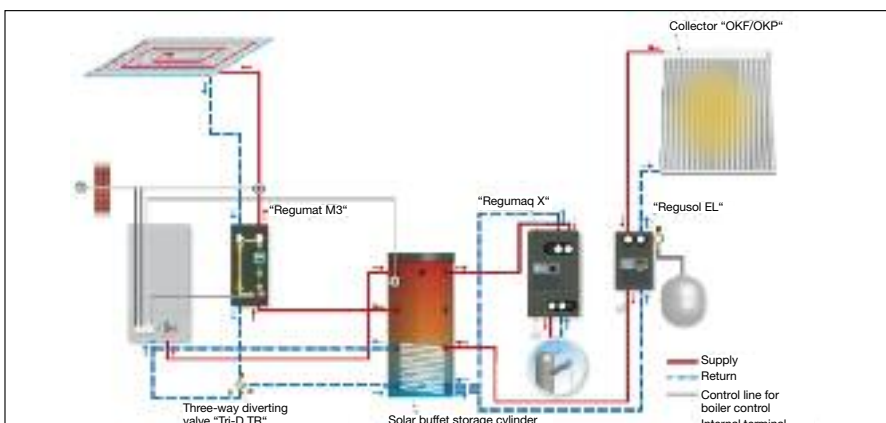

4



1

The tube collector "OKP-10/20" is a heat pipe tube collector which distinguishes itself by a permanent heat transport. Due to its hydronic features, the collector can be fixed to the building (pitched or flat roof, facade or detached) with an inclination of the axis between 15° and 75°.

The tube collector can be used for heating of potable or swimming pool water, solar support of the heating system and the production of process heat.

Due to the high-selective absorber surface, a high solar share is achieved.

The vacuum inside the tube guarantees maximum insulation. The high quality corrosion resistant materials ensure a long service life of the tube collector "OKP-10/20".

1 Tube collector "OKP-10/20" tested to DIN EN 12975 and certified according to "SolarKeymark". According to the ITW basic rules, the annual collector heat return amounts to 683 kW h/m². The collector heat return forecast is based on an aperture surface area of 3 m² (small illustr.: Foot rail with stainless steel angular plate for additional protection of the vacuum tubes on the roof)

2 Illustrated section tube collector "OKP-10/20"

Function:

- Sunlight is absorbed and converted into heat
- Heat is transmitted to the heat pipe via the heat conducting steel sheet inside the glass tube
- Liquid inside the heat pipe evaporates; steam rises into the condenser
- Heat is transmitted to the passing heat transfer medium via the double tube heat exchanger (collector) in which the condenser is located
- Liquid inside the condenser condenses due to the heat output, flows back inside the heat pipe and the procedure is repeated

3 System illustration solar circuit with collector

4 Simple installation of the roof hooks to the "OKP" frame profiles (lateral fitting)

Award:

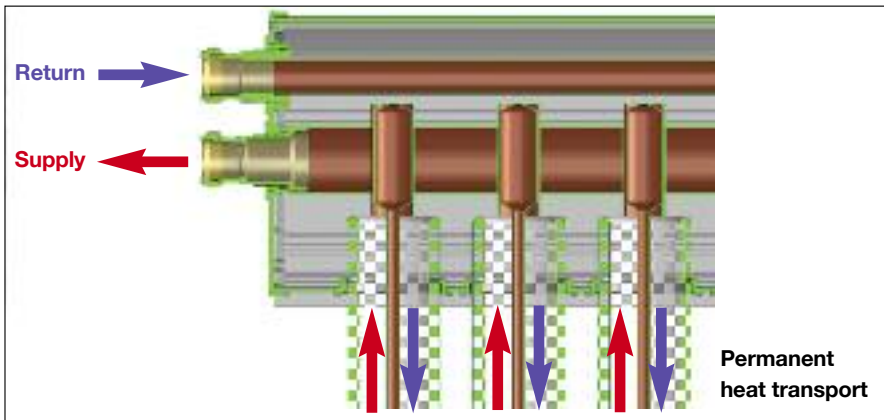
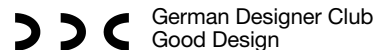

2

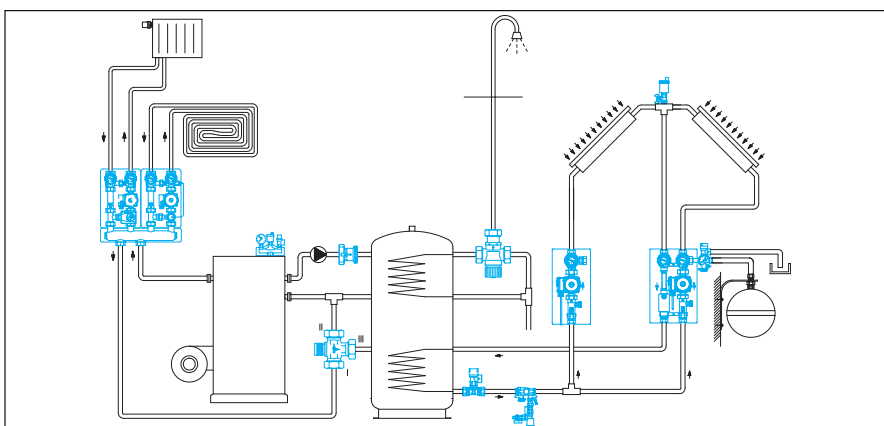

3



4



Flat-plate collectors “OKF-CK22/OKF-CS22” can be used for heating of potable and swimming pool water and for solar support of the heating system. The flat-plate collector can be mounted horizontally and vertically and is suitable for rooftop installation, roof integration and freestanding installation (flat roof installation).

Depending on the type of installation, basic sets for two collectors, extension sets for each additional collector and an individual collector set are available. The preassembled rail systems for rooftop and flat roof installation allow a quick and rational installation on site.

All fixing elements are easily accessible and allow a time-saving installation.

The absorber made of aluminium heat conducting steel sheet and copper pipe is connected to the solar circuit via two collector connections with G ½ male thread.

The flat-plate collectors are connected with one another by using flexible stainless steel corrugated pipes. Thermal conditional expansions are compensated at the same time.

1 Flat-plate collector “OKF-CK22” tested to DIN EN 12975 and certified according to “SolarKeymark”. According to the ITW basic rules, the annual collector heat return amounts to 499 kW h/m². The collector heat return forecast is based on an aperture surface area of 5 m².

2 Comparison

Antireflective glass (“OKF-CK22”) standard glass (“OKF-CS22”)

The antireflective glass of the flat-plate collector “OKF-CK22” increases transmission by 5%. Especially during winter, with an inclined incidence of light, the transmission is improved considerably compared with standard glass.

The water does not form drops on the nanostructure of the antireflective glass but drains away like a thin film (“no drop effect”).

3 Construction of the flat-plate collector

1

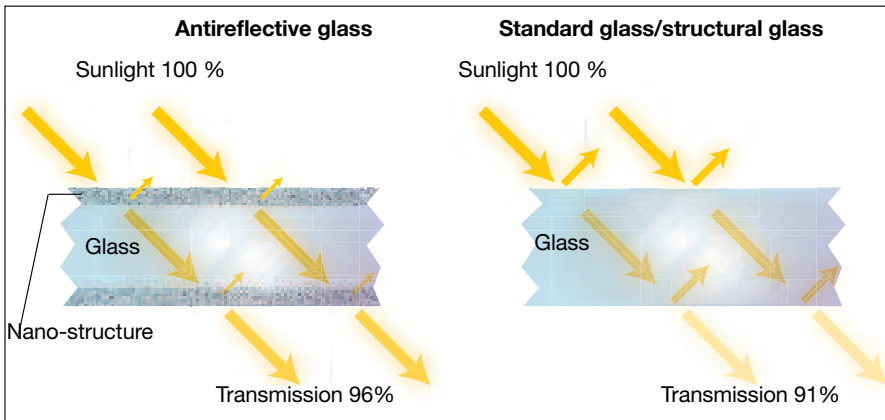

2

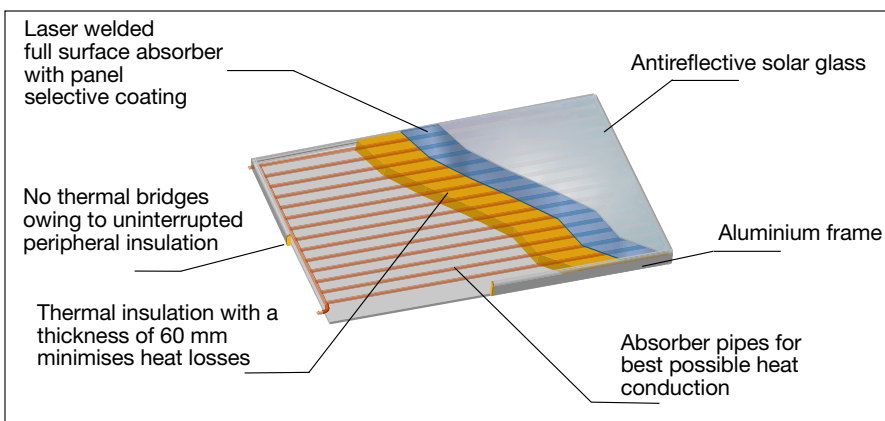

3

6



1 Station "Regusol ELH-130-B" with safety group (pump length 130 mm) with electronic controller "Regtronic RC-B" and deaerator for an effective deaeration of the heat transfer medium in the supply.

Connection to the solar circuit DN 25 using compression fittings "Regusol". Completely preassembled and leak tested station with safety group and facility to connect an expansion tank.

2 Station "Regusol S-130" with safety group (pump length 130 mm) but without electronic controller and without deaerator.

Connections:

DN 20: G 3/4 male thread (compression fittings according to DIN V 3838)

DN 25: G 1 male thread (for "Regusol" compression fittings)

3 Station "Regusol L-130" without electronic controller.

Connections as station "Regusol S-130".

4 Pump circuit "Regusol P-130" with safety group. Check valve integrated in the ball valve.

Connections as station "Regusol S-130".

5 Station "Regusol EL-130-B" with electronic digital controller.

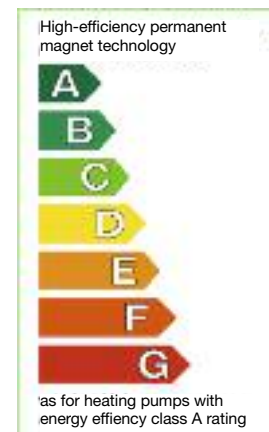

1



2



3



4



5



1 Station "Regusol L-180" DN 25 with safety group (pump length 180 mm) and deaerator for an effective deaeration of the heat transfer medium in the supply. Connection to the solar circuit DN 25 using compression fittings "Regusol". Completely preassembled and leak tested station with safety group and facility to connect an expansion tank.

2 Pump circuit "Regusol P-180" DN 25 with safety group.

3 Station "Regusol S-180" DN 25, same construction as station "Regusol L-180" but without deaerator.

4 Station "Regusol S-180" DN 32 with safety group. Connection to the solar circuit G 2 flat sealing.

1



2



3



4

8



1

Product assembly with electronic controller and heat exchanger for a controlled transmission of the heat of the solar circuit (primary circuit) to a buffer storage cylinder (secondary circuit), for instance for existing storage cylinders without direct solar connection.

Primary circuit up to PN 10 and 120°C, starting temperature 160°C.

Secondary circuit up to PN 6 and 120°C, constant operation.

The soldered plate heat exchanger complies with the specifications of the European Pressure Equipment Directive (PED). Due to turbulent flow conditions, an excellent self-cleaning effect is produced and a contamination is avoided.

The solar circuit is protected against excess pressure by a safety group integrated in the heat exchanger system. The leak tested components of the plate heat exchanger system are mounted on a board. The controller is cabled with the internal electric components and has the following connections:

- Output for solar circuit pump
- Output for loading pump
- Temperature entries for:
 - Collector, heat exchanger entry point – primary side, heat exchanger exit point–secondary side, 2 temperature entries for buffer storage cylinder, interface for electronic flow sensor.

Plain text display of the controller and data output (S-bus). The heat exchanger system is completely insulated and can quickly be connected to the primary side using compression fittings and to the secondary circuit using flat seals and be put into operation.

The actual heat transmission depends on:

- the achieved flow temperature and the flow rate of the primary circuit
- the flow temperature difference between the primary and the secondary circuit
- the required flow temperature and the flow rate of the secondary circuit

Model:

- **"Regusol X-Uno 25-B"**
Station with heat exchanger
1 solar circuit connection/
1 loading circuit connection
with electronic controller "Regtronic RX-B"
number of heat exchanger plates: 30

- 1** "Regusol X-Uno"
- 2** System illustration

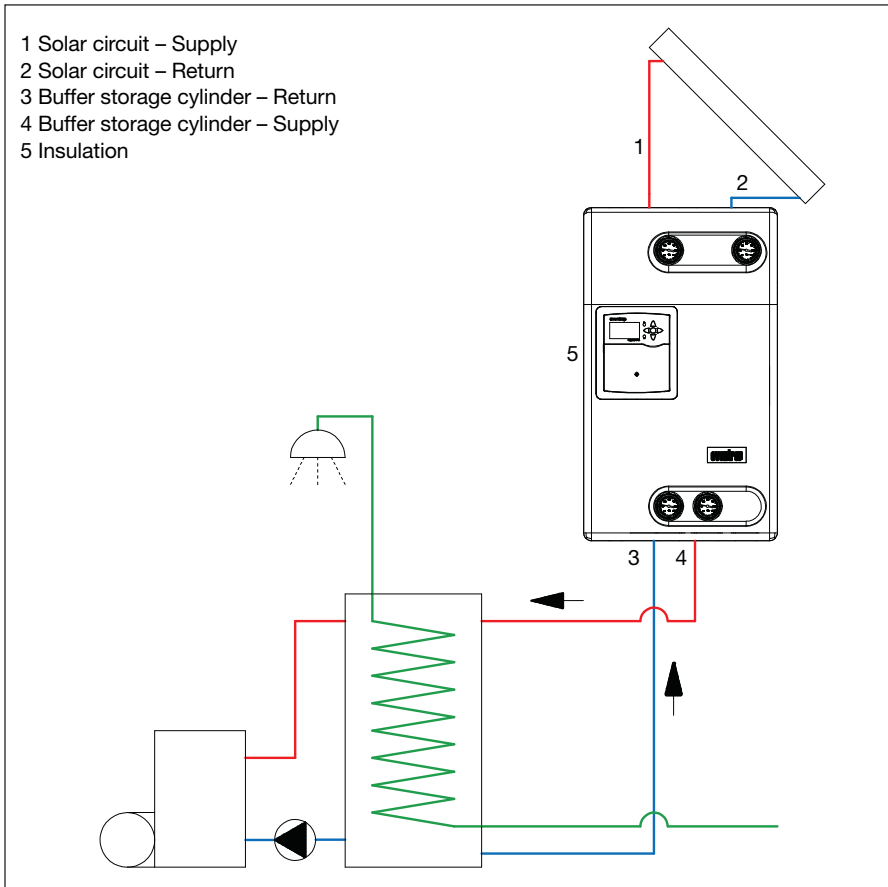

2



Product assembly with electronic controller, heat exchanger, three-way conversion valve for second loading circuit for the controlled transmission of the heat of the solar circuit (primary circuit) to a buffer storage cylinder (secondary circuit), for instance for existing storage cylinders without direct solar connection.

The three-way valve integrated in the supply pipe of the secondary circuit allows the conversion to an additional loading circuit running in parallel, for instance for the loading section by section of the storage cylinder or the thermal loading of another storage cylinder.

Primary circuit up to PN 10 and 120°C, starting temperature 160°C.
Secondary circuit up to PN 6 and 120°C, constant operation.

The soldered plate heat exchanger complies with the specifications of the European Pressure Equipment Directive (PED). Due to turbulent flow conditions, an excellent self-cleaning effect is produced and a contamination is avoided.

The solar circuit is protected against excess pressure by a safety group integrated in the heat exchanger system. The leak tested components of the plate heat exchanger system are mounted on a board. The controller is cabled with the internal electric components and has the following connections:

- Output for solar circuit pump
- Output for loading pump
- Output for conversion valve

- Temperature entries for:
 - Collector, heat exchanger entry point – primary side, heat exchanger exit point – secondary side, 3 temperature entries for storage cylinder with loading operation section by section, interface for electronic flow sensor.

Plain text display of the controller with data output (S-bus).

The heat exchanger system is completely insulated and can quickly be connected to the primary side using compression fittings and to the secondary circuit using flat seals and be put into operation.

The actual heat transmission depends on:

- the achieved flow temperature and the flow rate of the primary circuit
- the flow temperature difference between the primary and the secondary circuit
- the required flow temperature and the flow rate of the secondary circuit

Model:

- **"Regusol X-Duo 25-B"**
Station with heat exchanger
1 solar circuit / 2 loading circuit
connections with electronic controller
"Regtronic RX-B" number of heat exchanger plates: 30

1 "Regusol X-Duo"

2 System illustration

1

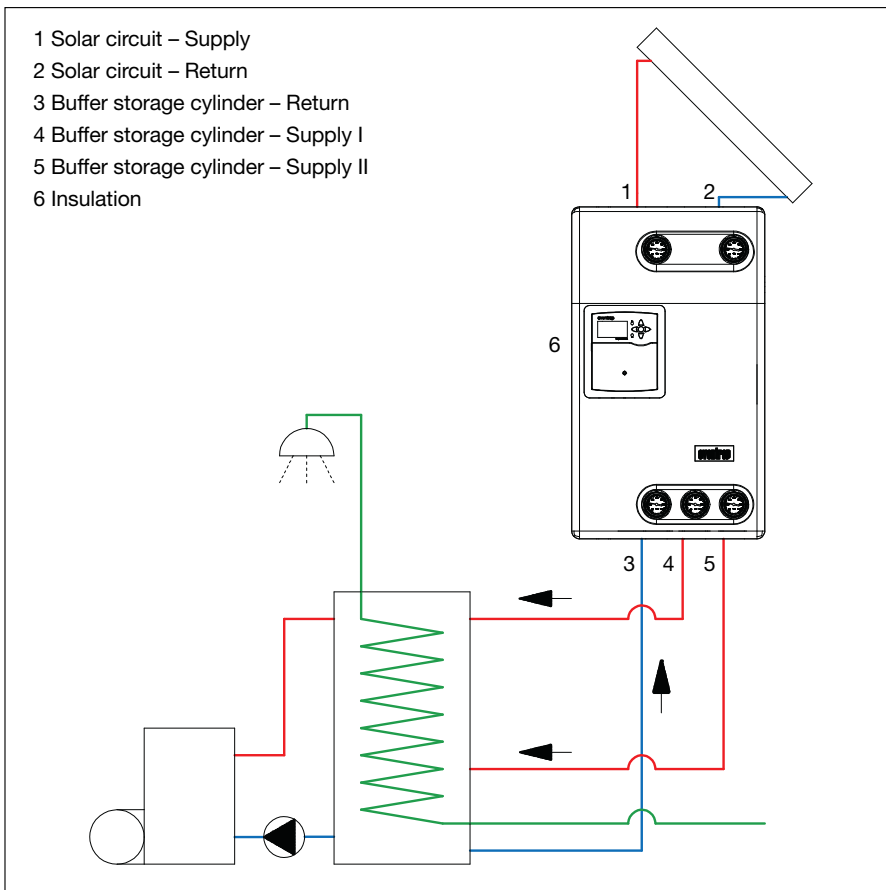

2

System illustration

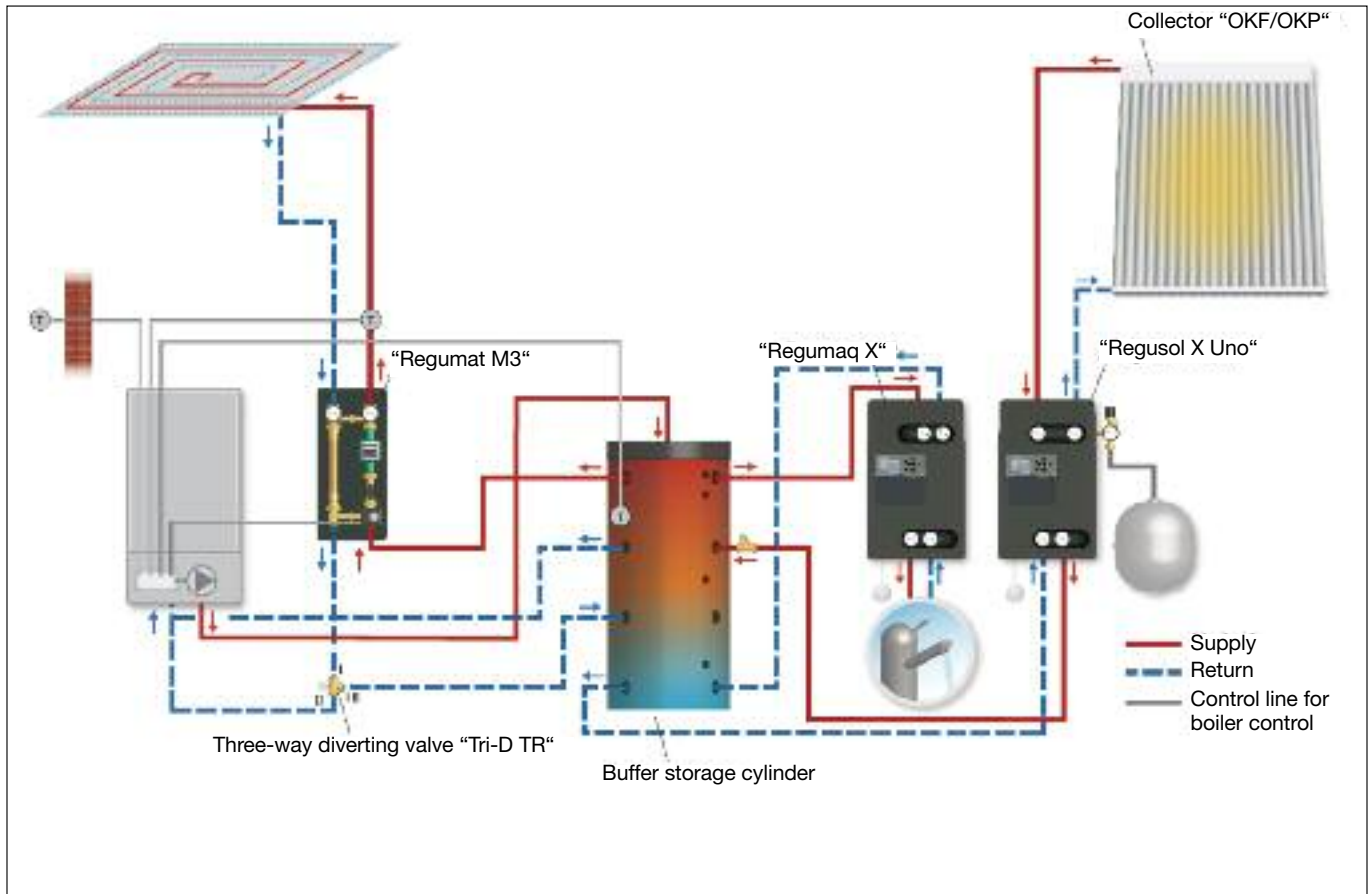

Solar circuit

The solar plant is connected and controlled via the station “Regusol X-Uno” with integrated heat exchanger and the integrated controller “Regtronic RX-B”.

Reloading of the buffer storage cylinder

The buffer storage cylinder is reloaded by the boiler depending on the storage cylinder sensor (T).

Hot potable water

Hot potable water is supplied by the station for heating of potable water “Regumaq X” when needed.

No hot potable water is stored; therefore the installation is hygienically safe.

Support of the heating system and return temperature increase

The flow temperature is controlled via the existing boiler control. The mixing valve of the “Regumat M3” station is activated depending on the outside temperature.

In order to use the solar energy in the storage cylinder, a return temperature increase is realised via the controller “Regtronic RX-B”. If the return temperature is lower than the storage cylinder temperature, the three-way diverting valve “Tri-D TR” is switched to port III.

Energy for return temperature increase is taken from the storage cylinder.

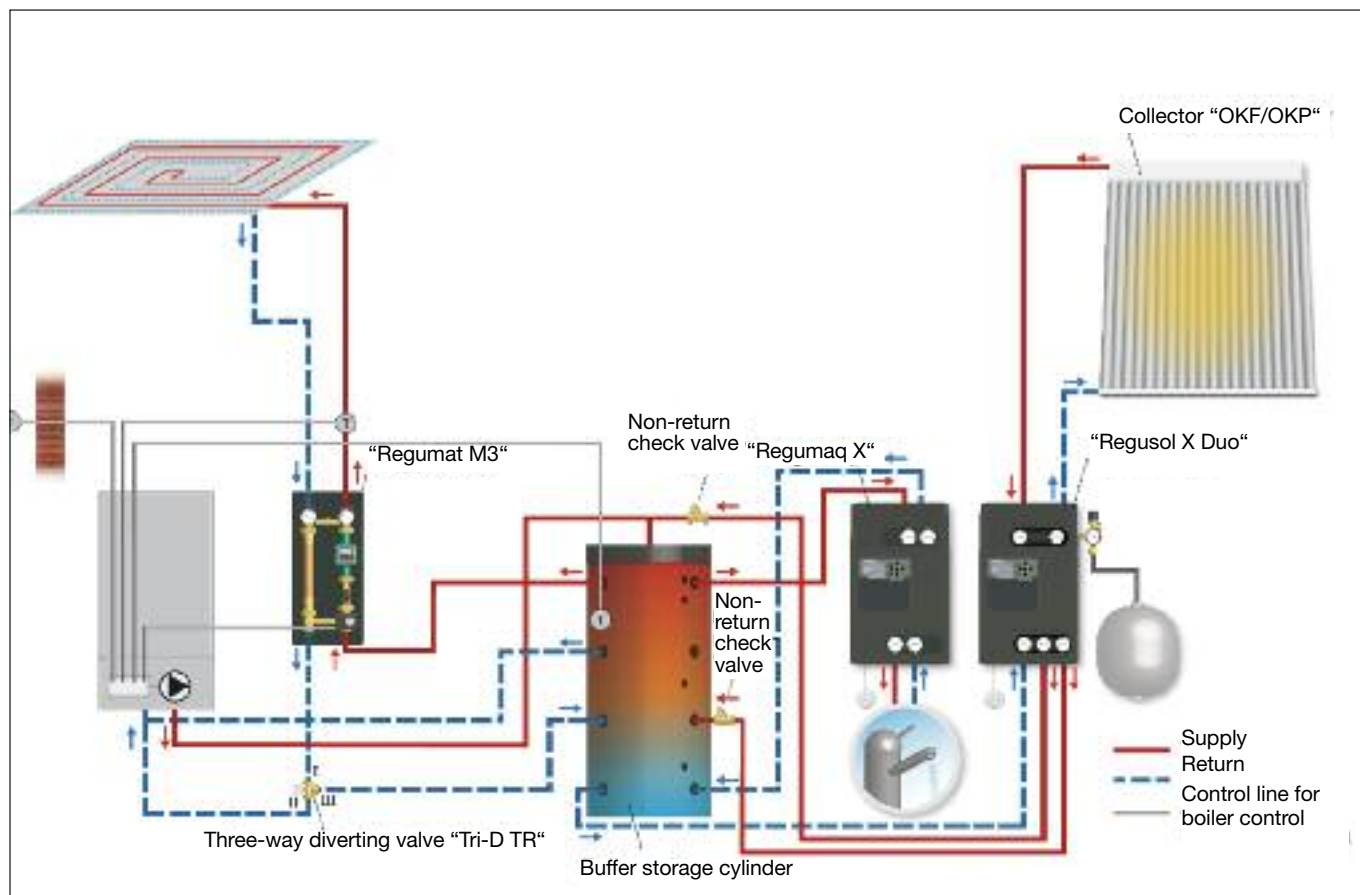

Solar circuit

The solar plant is connected and controlled via the station “Regusol X-Duo” with integrated heat exchanger and the integrated controller “Regtronic RX-B”. Depending on the temperatures available in the collector circuit, the station “Regusol X-Duo” allows a loading of the storage cylinder section by section. High temperatures are stored in the upper and low temperatures in the middle section of the storage cylinder. This way, efficiency of the solar plant is increased.

Reloading of the buffer storage cylinder

The buffer storage cylinder is reloaded by the boiler depending on the storage cylinder sensor (T).

Hot potable water

Hot potable water is supplied by the station for heating of potable water “Regumaq X” when needed.

No hot potable water is stored; therefore the installation is hygienically safe.

Support of the heating system and return temperature increase

The flow temperature is controlled via the existing boiler control. The mixing valve of the “Regumat M3” station is activated depending on the outside temperature.

In order to use the solar energy in the storage cylinder, a return temperature increase is realised via the controller “Regtronic RX-B”. If the return temperature is lower than the storage cylinder temperature, the three-way diverting valve “Tri-D TR” is switched to port III.

Energy for return temperature increase is taken from the storage cylinder.



1



2

„Regumaq X-30-B“

The Oventrop station “Regumaq X-30-B” is an electronically controlled product assembly with heat exchanger for the hygienic heating of potable water on the flow principle. The potable water is only heated at the time when it is needed, i.e. “just in time”. A hot potable water reserve is thus not necessary.

The product assembly allows an optimum realisation of regenerative pipework configurations. The stations are especially suitable for detached and semi-detached houses. They are connected to buffer storage cylinders which are heated up by solar energy, solid fuels, gas or oil.

Depending on the temperature and the flow volume on the potable water side (secondary circuit), the circulation pump on the buffer side (primary circuit) is speed regulated.

The plate heat exchanger can be flushed using the fill and drain cocks integrated in the primary and secondary circuit. Due to the turbulent flow, a good self-cleaning effect avoiding a contamination is achieved.

The potable water circuit is protected by a 10 bar safety valve.

The leak tested components of the heat exchanger system have flat sealing connections and are mounted on a board.

“Regumaq XZ-30-B”

The Oventrop station “Regumaq XZ-30-B” for heating of potable water is identical to the station “Regumaq X-30”, but the product assembly for the operation of circulation systems is additionally equipped with a circulation pump in the potable water circuit.

The controller is fully cabled with the internal electric components and serves to control the following additional functions:

- Demand: The circulation function is activated if water is drawn off for a short period
- Cycle: The circulation pump runs according to the set time switching
- Temperature control: the circulation pump runs dependant on the return temperature
- Three switching points within the corresponding operating mode can be programmed each day

1 “Regumaq X-30-B” station for heating of potable water with electronic controller

2 “Regumaq XZ-30-B” station for heating of potable water with electronic controller and additional potable water circulation

3 System illustration “Regumaq X-30-B”

4 Draw off capacities (Q secondary) of the “Regumaq” station depending on the temperature in the buffer storage cylinder

Example (see illustr. 4):

If a temperature of 45°C is set at the controller, a draw off volume flow of 30 l/min. (Q secondary) can be achieved with a water temperature of 60°C inside the buffer storage cylinder and a required volume flow of 25 l/min. in the buffer circuit.

The primary volume flow is modified by the pump in the storage cylinder circuit which is activated by the controller.

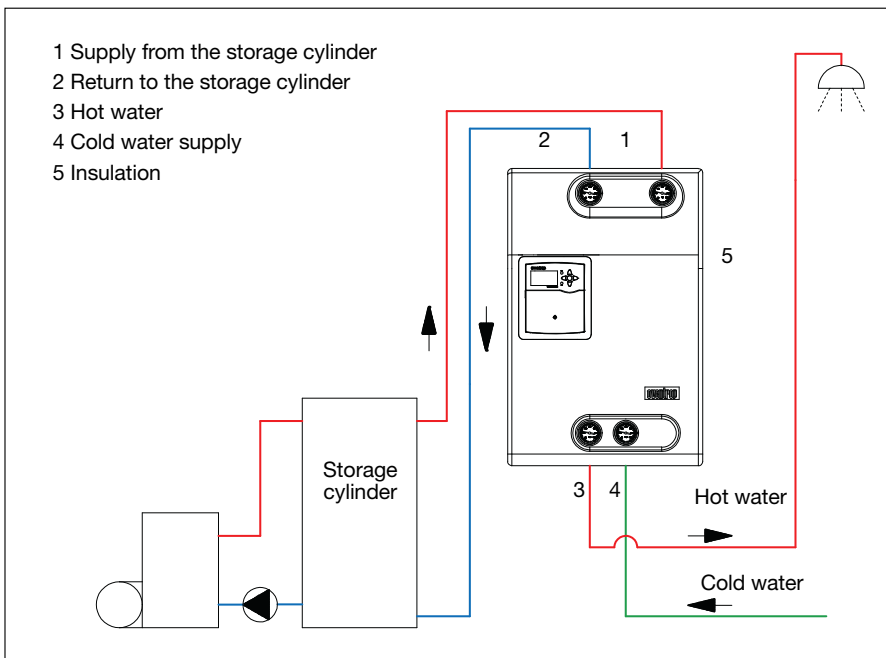

3

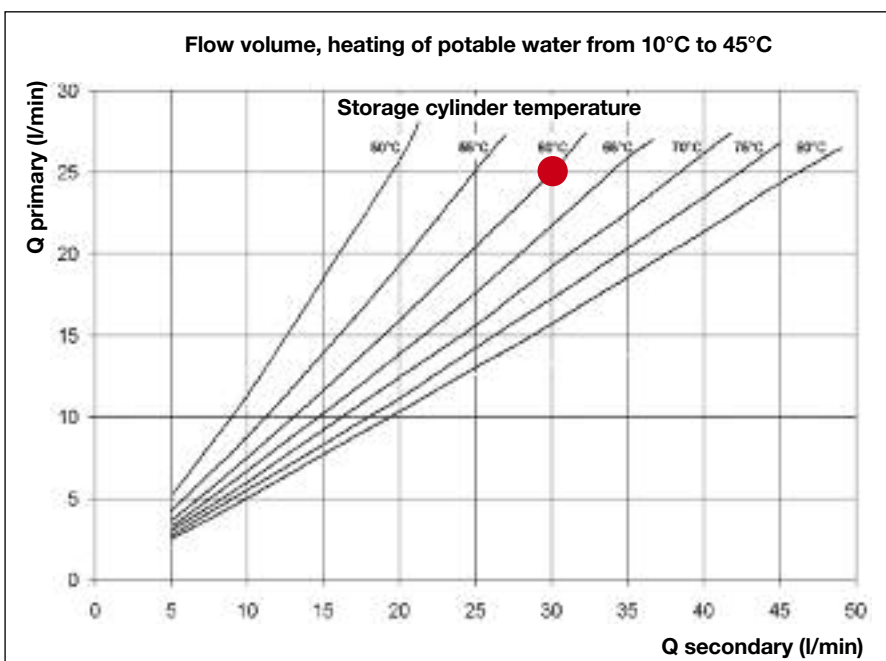

4



Cascade control set “Regumaq XK”

consisting of:
Cascade control and actuators with ball valves for potable water supply.
The cascade control set allows to increase the discharge capacity of the stations “Regumaq XZ-30-B” up to 120 l/min.

Models:

- Set for the control of 2 “Regumaq XZ-30-B” stations
Discharge capacity: 60 l/min. with a hot water temperature of 50°C and a cold water temperature of 10°C
2 actuators with ball valve
- Set for the control of 3 “Regumaq XZ-30-B” stations
Discharge capacity: 90 l/min. with a hot water temperature of 50°C and a cold water temperature of 10°C
3 actuators with ball valve
- Set for the control of 4 “Regumaq XZ-30-B” stations
Discharge capacity: 120 l/min. with a hot water temperature of 50°C and a cold water temperature of 10°C
4 actuators with ball valve

- 1 “Regumaq XZ-30-B” with “Regumaq XK”
- 2 System illustration

1

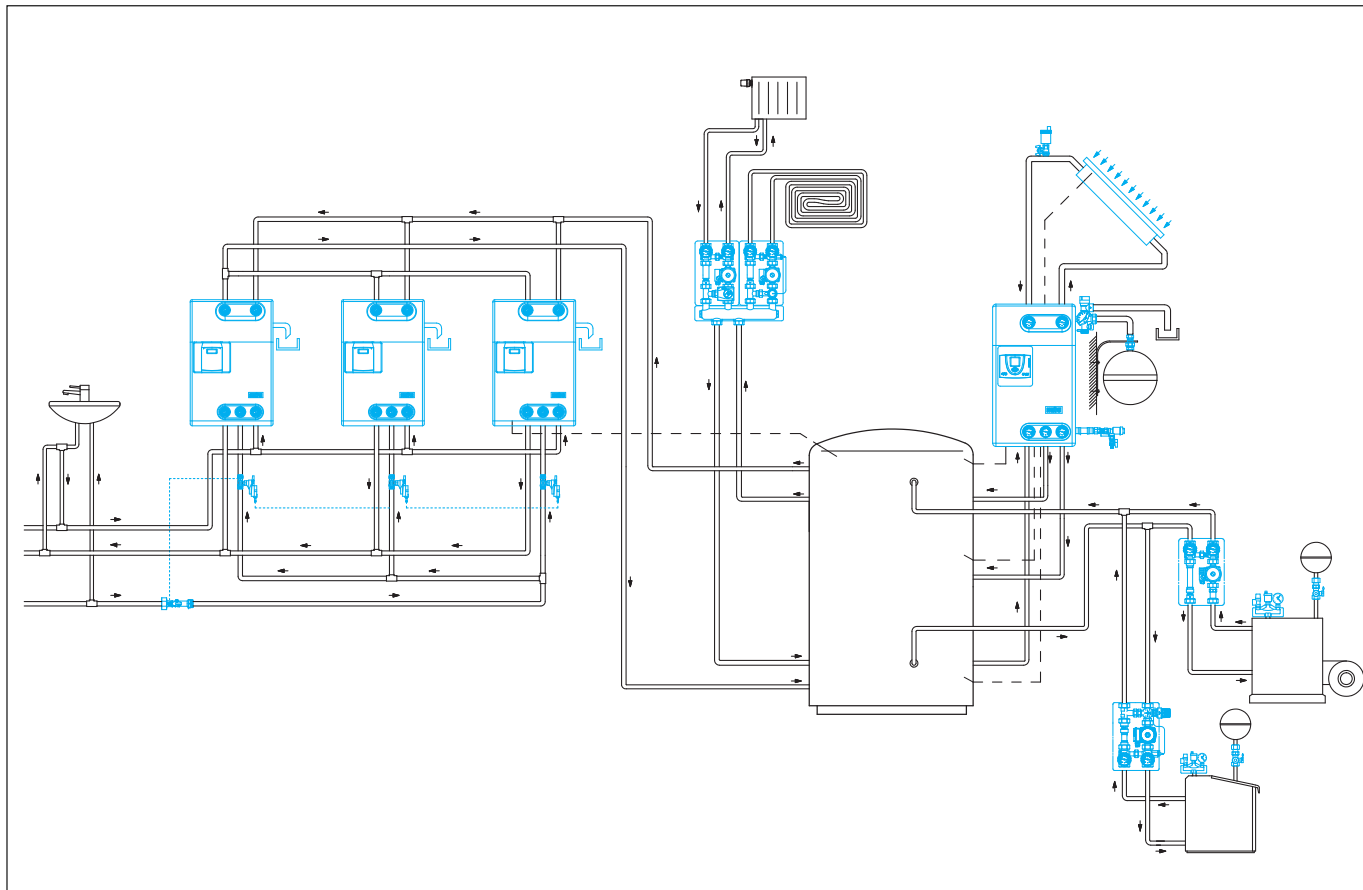

2



Electronic controller for wall attachment with preinstalled switching schemes for the control of a solar thermal plant and/or for heating circuit regulation.

The combination of preinstalled switching schemes and freely adjustable additional functions allows the controller to perform complex controls.

1 Solar controller “Regtronic B2/2-B”

Simple collar controller for wall attachment for the control of a solar plant for hot water preparation with one collector and one storage cylinder.

- 4 sensor inputs
- 1 output
- 1 data output S-bus

2 Heating circuit controller “Regtronic RH-B”

Weather guided control of the flow temperature of the heating system via the demand of a heat generator and/or a mixing valve (e.g. “Regumat M3” or “Regufloor HW” with three-way mixing valve). The heating circuit controller may control one variable temperature circuit and one constant temperature circuit with heat demand.

Extendable to up to 6 variable temperature circuits and 6 constant temperature circuits via the extension module “Regtronic EM-B” (item no. 1152098).

- 8 sensor inputs
- 2 inputs for electronic volume flow sensors
- 5 outputs (one of them volt free relay)
- 2 PWM/0-10 V outputs (convertible)
- 1 data output S-bus
- SD-card slot

3 System controller “Regtronic RM-B”

The system controller controls solar plants with East-West roof orientation and several storage cylinders as well as weather guided variable / constant temperature circuits. Different loading functions such as storage cylinder loading section by section, heat exchange, heat demand, boiler loading, solid fuel boiler, mixing valve control, measurement of heat consumption, tube collector function, drain back option, thermostat function, ΔT -regulation, thermal disinfection, circulation and further functions may be activated via the intuitive user command. Up to 5 extension modules “Regtronic EM-B” (item no. 1152098) can be connected to the “Regtronic RM-B”. Thus, there is a total number of 39 relay outputs for individual pipework configurations.

- 12 sensor inputs
- 4 inputs for electronic volume flow sensors
- 3 pulse inputs
- 14 outputs (one of them volt free relay)
- 4 PWM/0-10 V outputs (convertible)
- 1 data output S-bus
- SD-card slot

4 System illustration

1



2



3

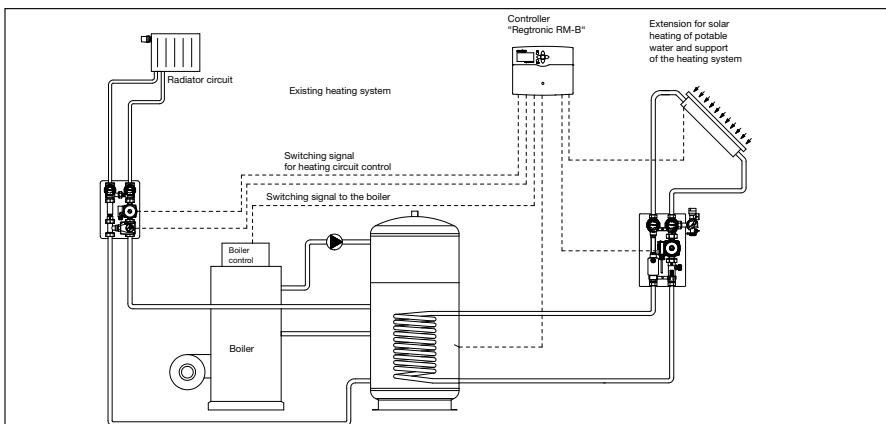

4

The Oventrop controllers allow for a number of possible pipework configurations. Amongst others, functions like return temperature increase, boiler activation, wood burning boiler activation, circulation function, threshold function as well as heating and cooling function can easily be realised.

The below mentioned pipework configurations can be realised with the Oventrop controllers.

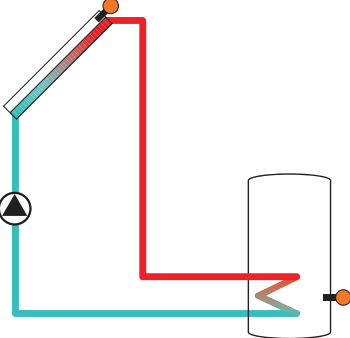
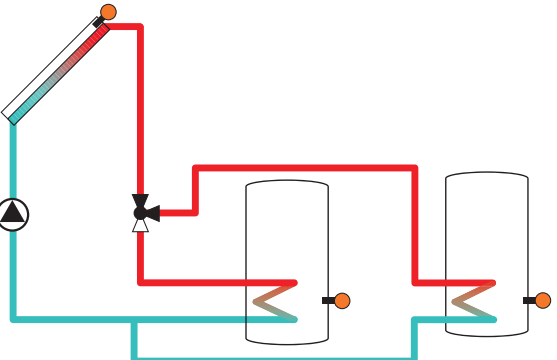
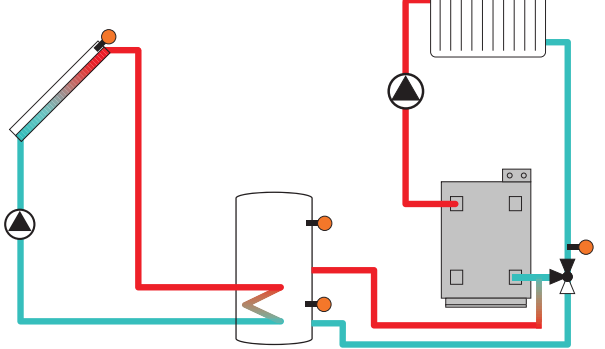
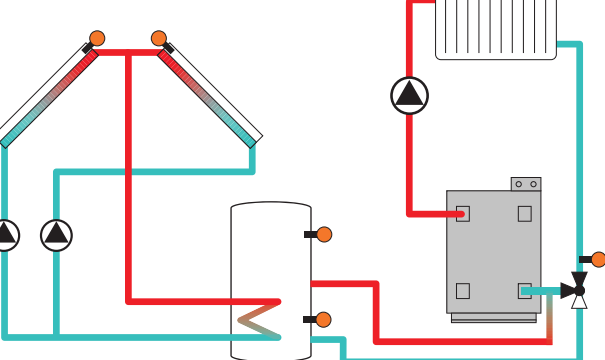
Pipework configuration	“BS/2-B“	“RC-B“	“RM-B“
	X	X	X
		X	X
		X	X
		X	X

Further pipework configurations can be found in the catalogue “Products”, product range 7.



Heating systems with regenerative energy sources consist of various components. They are often installed separately and have to be coordinated.

This problem is solved by the Oventrop energy storage centre “Regucor WHS”. It consists of a heating water storage cylinder for efficient heat storage and components which are hydraulically coordinated. The heat management of the integrated system controller guarantees an optimum interaction between the heating water storage cylinder and all other components.

The “Regucor WHS” which allows a time- and space-saving installation can be connected to different heat generators. The Oventrop energy storage centre “Regucor WHS” consists of:

- Solar station
- Hot water preparation
- Heating circuit connection
- Heat storage
- Heat generator connection (e.g. boiler, heat pump etc.)

1 Energy storage centre “Regucor WHS”

1



The storage cylinder stores the water heated by solar energy.

Buffer storage cylinders are available as solar buffer storage cylinder with internal heat exchanger for the solar circuit or as pure buffer storage cylinder without heat exchanger.

The most common potable water storage cylinders in a solar plant are referred to as bivalent storage cylinders as the storage cylinder cannot only be loaded with the help of solar energy but it can also be reloaded by another energy source. This type of storage cylinder features two internal heat exchangers.

The bivalent storage cylinders for potable water should not be oversized as this presents a risk of germs and hygiene can be impaired.

The rule-of-thumb for dimensioning in Central Europe is as follows:

Hot water preparation:

Storage cylinder volume of about 50 litres per square meter of installed aperture surface area.

2 Puffer storage cylinder “Hydrocor HP”

3 Solar buffer storage cylinder “Hydrocor HS”

4 Bivalent potable water storage cylinder “Hydrocor WB”

2

3



4



1



2

1 Special expansion tank for solar plants with a nominal volume of 18, 25, 33, 50 or 80 l.

Permissible operating temperature 70°C
Max. operating pressure 10 bar

Diaphragm tested according to DIN 48 03 T3; approved according to Pressure Equipment Directive (PED) 97/23 EC.

2 Inline tank with a nominal volume of 6, 12 or 20 l for the protection of the diaphragm expansion tank and the solar station from excess temperatures.

The inline tanks are for instance required if the “OKF” flat-plate collectors are installed vertically or in central roof heating systems with short pipes.

Max. operating pressure: 10 bar
Approved according to Pressure Equipment Directive (PED) 97/23/EC.

3 Oventrop offers an extensive range of accessories (e.g. stainless steel corrugated pipe for roof conduit, connection fittings for series coupling of several “OKP-10/20” collectors into a large collector field) for the connection of “OKP-10/20” tube collectors (see also page 5).

Without illustr.: Oventrop offers different connection fittings, flat sealing or with compression connection, for the flexible connection of the “OKP-10/20” tube collectors to the solar circuit.



3



1



2



3



4



5



6



7



8

9

1 Flow measuring and regulating device with isolation, for instance for "Regusol-130", 2-15 l/min.

2 Venting circuit for replacement at existing stations "Regusol-130" consisting of: Ball valve with integrated check valve, thermometer and deaerator.

3 Filling and flushing device "Regusol" Isolating ball valve with lateral connection for filling and flushing pipes to be installed at the lowest point of the solar circuit.

4 Filling pump "Regusol" Manual filling pump with hose connection and ball valves on suction and pressure side.

5 Three-way mixing valve and temperature controller with immersion sensor, is used for industrial installations, water heaters, air heaters, dishwashers, surface heating systems or similar. The control range can be limited or locked.

6 Connection set "Regusol" For the connection of a diaphragm expansion tank to the solar station "Regusol". Consisting of: Steel angled wall bracket, quick coupling for diaphragm expansion tank and a corrugated pipe.

7 Circulation station "Regucirc M" for bivalent storage cylinders. The thermal insulated pump assembly consists of a thermostatic mixing valve (35°C – 65°C) with fail-safe function, non-return check valves and isolating ball valves with integrated thermometers. The station is installed between the bivalent potable water storage cylinder and the circulation system. The station serves to adjust the temperature of a hot water circulation system to the value set at the thermostatic mixing valve even if no hot water is drawn off.

8 Thermostatic mixing valve "Brawa-Mix" made of bronze, for domestic water installations PN 10 up to 100°C. Control range: 35-50°C

9 Brass ball valve "Optiflex" with male or female thread, self-sealing, with counter nut, handle with limit stop, with hose connection (soft seal) and cap.



1



2

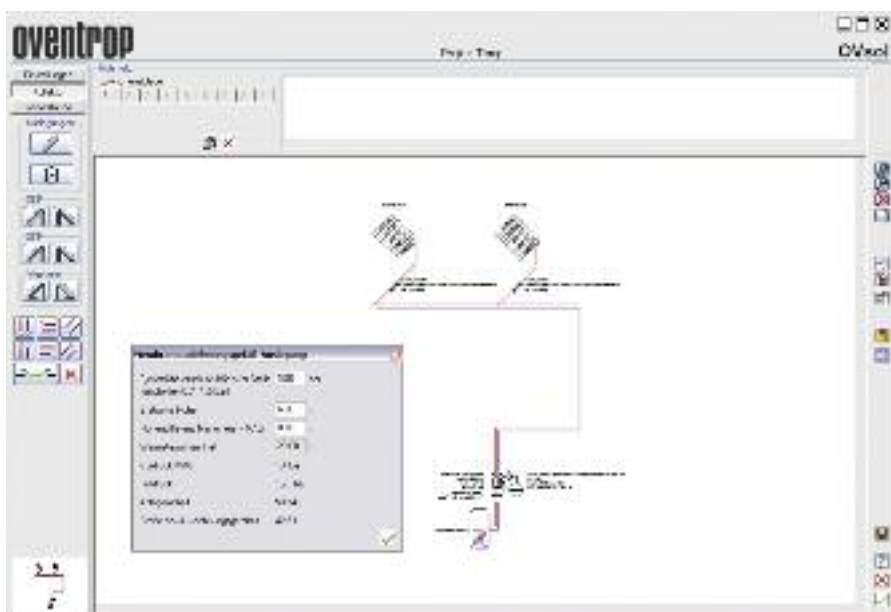

3

1 Oventrop support their partners with theoretical and practical seminars. Competent instructors report on current guidelines, standards and possible statesponsorships.

Practical examples clarify the correct design and the useful integration of Oventrop components and complete systems for the solar circuit, hot water preparation and support of the heating system (including underfloor and wall heating).

2 The design of a solar plant can be carried out online in the software menu of the Oventrop homepage www.oventrop.de. Distinction is made between hot water preparation and hot water preparation with support of the heating system. A worldwide climate data bank can be accessed. The number of collectors and the suitable storage cylinder size are calculated according to the consumption-related data for instance number of persons, heat load or energy consumption. The calculation supplies information on the heat return, share and CO₂ savings.

3 The efficiency of a solar thermal plant depends on the hydronic integration and dimensioning. Especially the solar network has to be designed to the optimum to avoid a reduction of the efficiency by unnecessarily high pump outputs. Dimensioning of the components is carried out with the help of the Oventrop solar calculation programme "OVsol". Depending on the choice of a high or low flow system, the programme determines the volume flow, the pipe diameter, the pump head and the volume of the diaphragm expansion tank. Above all, the presetting values of solar double regulating and commissioning valves for the hydronic balance of several collector fields can be calculated.

Both programmes can be downloaded or used on the Oventrop homepage free of charge.

Further information can be found in the Oventrop catalogue "Products", in the technical data sheets as well as on the internet, product ranges 6 and 7.

Subject to technical modifications.

For an overview of our global presence visit www.oventrop.de.

F. W. OVENTROP GmbH & Co. KG
 Paul-Oventrop-Straße 1
 D-59939 Olsberg
 Germany
 Phone +49 (0) 29 62 82-0
 Fax +49 (0) 29 62 82-450
 E-Mail mail@oventrop.de
 Internet www.oventrop.de